



FLORAL DESIGN COMPETITION – COMPETITOR BRIEF

SHOW BACKGROUND

The Melbourne International Flower & Garden Show returns to the heritage-listed Royal Exhibition Building and Carlton Gardens South for the 28th edition of the largest horticultural event in the Southern Hemisphere. The Show will be hosted from 26th to 30th March and anticipate hosting over 100,000 visitors across the 5 days.

The Show provides the leading platform for professional, emerging and student designers across a range of skills within the Floral and Garden industries. Each year, several competitions are curated to give participants the opportunity to showcase their abilities and be in the running for highly prestigious awards. An award at the Show provides a lasting recognition of quality, reaching an audience far wider than the substantial number of attendees that visit the Show.

COMPETITION OVERVIEW

The **Floral Design Competition** is the preeminent floral competition at the Melbourne International Flower & Garden Show. This competition is designed to celebrate the principles and mechanics of floral design and is intended to highlight the best designers from the industry in a format that has been a consistent feature at the Show for many years.

For 2025, the number of spaces available in the **Floral Design Competition** have been limited, providing an exciting opportunity for professional designers to put their designs on Show against the strongest peers within the Floral industry.

The **Floral Design Competition** will be open to applications for all interested floral designers until Friday 13th December. Applications can be made by completing the form available on the website, available through the below link.

<https://melbflowershow.com.au/floral-design-competition/>



THEME

SHOW THEME

For the 2025 Show, the theme for the Royal Exhibition Building and the floral displays within is:

The Future of Floristry: An Innovative Break with Tradition

The theme for the 2025 edition is inspired by the impact of one of the great artistic pioneers: **Claude Monet**. Just as Monet, amongst several artists during the period of Impressionism, broke with tradition and redefined the boundaries of art, this year's Show invites florists and competitors to challenge convention and create something truly transformative.

Please refer to the provided 'Theme Overview' document for more detail on the Theme for 2025.

COMPETITION THEME

While each of the Key Characteristics within the 'Theme Overview' should be considered within the design of each floral display for 2025, certain characteristics will be linked to each competition to provide greater direction for designers. This will provide a degree of variety for Show visitors and allow designers to attach themselves to the characteristics which they most align with from a creative perspective.

The Key Characteristic for the **Floral Design Competition** is:

Atmosphere and Mood - Capture a sense of mood and atmosphere, designing displays that transport the viewer to a specific moment or place. Create an immersive experience with your arrangement by evoking a particular time of day, season, or emotion. Use a combination of colours, textures, and scents to build a multisensory experience.

Note - Although only one Key Characteristic has been highlighted to provide a clear direction for designers in the Competition, all competitors are reminded each Key Characteristic is important in creating the desired impact of the overall theme in the final design.

DESIGN NOTES

Adherence to Theme

Ensure your installation captures the theme of "*The Future of Floristry – An Innovative Break with Tradition*", taking inspiration from the artistic use of innovation through colour blending and natural movement.

Innovation

Use innovative techniques to create the display. Push the boundaries while adhering to the principles of floral design.

Sustainability

This year's Show will shine a spotlight on sustainability. Competitors will be expected to incorporate environmentally conscious practices, choosing materials that reflect a respect for nature while staying true to the creative vision. By aiming to merge creative brilliance with ecological responsibility, emphasis will be placed on the use of eco-friendly mechanics and techniques that demonstrate innovation in sustainable floral design, including the omission of certain materials (referenced in the General T&C's section).

Principles & Elements of Floral Design

Display mastery of balance, rhythm, proportion & scale, contrast & dominance, colour and harmony.

Wow Factor & Storytelling

Your installation must tell a compelling story with a strong "wow" factor, evoking a captured moment in time through innovative use of florals, foliage, and accessories.

Longevity

Design your installation to consider the longevity of the display ensuring that the installation remains visually stunning for the duration of the event.

Audience

The installation must present a 270-degree view, making it visually impactful from all angles. The designs will be at least 1.5m (on the 3m side) from the next design in 2025, allowing visitors to view more of the display.



SITE LAYOUT

Participants will be provided with the following infrastructure and space to create their display.

- 6m wide custom design Backdrop (height 2.4m)
- 6x3m space (6m frontage)
- Kickboards around sides and front to define space during show
- 1 x power outlet (if desired) to use within display
- Black plastic laid on floor of display space

The below image is an indicative layout, noting each display will be on one side of the wall only.

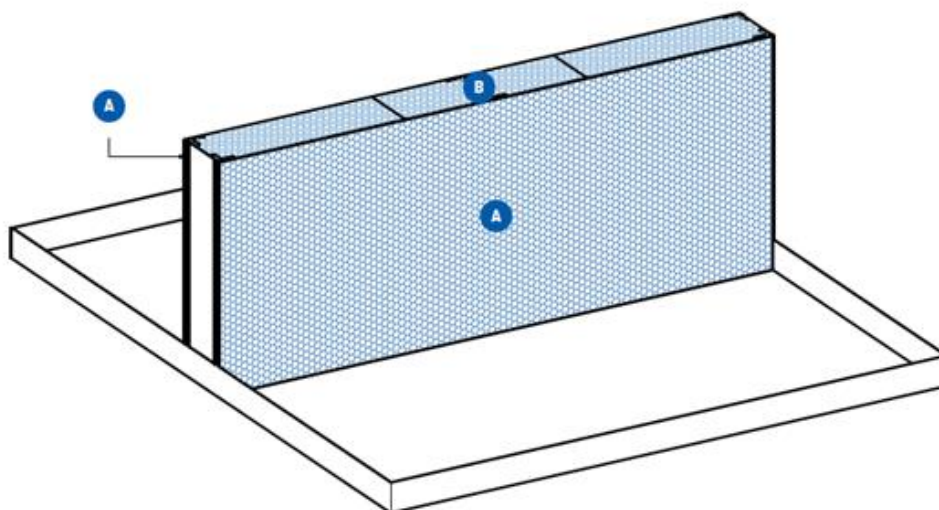

Participants are not permitted to exceed the width (6m), depth (3m), or height (2.4m) with any part of their display.

The black plastic is laid to prevent damage to and water spillage on the floor of the venue during the bump-in. Participants are responsible for removing the black plastic prior to the completion of their display.

CUSTOM BACKDROP

Participants will be able to provide a custom design to use as the backdrop for their display. All backdrops will be produced by Harry the Hirer and installed prior to arrival on site. Further details on this process will be provided closer to the Show.

COMPETITION INFORMATION

COMMERCIAL CONTRIBUTION

All successful applicants will be provided with a commercial contribution of \$1,000 ex GST.

The commercial support is provided as a contribution towards the construction of the display, including the associated costs of labour and materials. For the avoidance of doubt, all additional costs will be the responsibility of the participant.

All payments are subject to receipt by the Organiser of a valid tax invoice with no less than thirty (30) day terms. For the avoidance of doubt, all payments will be made after the conclusion of the Show.

Participants reserve the right to obtain additional sponsorship to support their display at the Show. If the participant wishes to promote any sponsors within their display, they must first seek the approval of the Organiser. The Organiser reserves the right to disallow, within reason, any sponsorship which affects the display.

COMPETITION SCHEDULE

DATE	TIME	TITLE	DETAIL
23/3/2025	9:00am – 5:00pm	Installation	Site accessible to create display
24/3/2025	7:00am – 5:00pm	Installation	Site accessible to create display
25/3/2025	7:00am – 4:00pm	Installation	Site accessible to create display. Participants must leave site prior to judging commencement
25/3/2025	4:30pm	Judging	Formal Judging commences
26/3/2025	2:00pm – 3:00pm (TBC)	Floral Award Presentations	Participants to be present
30/3/2025	5:30pm – 9:00pm	Bump Out	Site accessible to pack down display
31/3/2025	7:00am – 10:00am	Bump Out	Site accessible to pack down display

JUDGING OVERVIEW

CRITERIA

Interpretation of Theme (10 Marks)	
Overall Impact (25 Marks)	
Originality, Creativity, and Innovation	10 Marks
Use of Colour	10 Marks
Floral Content	5 Marks
Principles & Elements of Design (40 Marks)	
Line	5 Marks
Balance	5 Marks
Rhythm	5 Marks
Proportion & Scale	10 Marks
Contrast & Dominance	10 Marks
Harmony	5 Marks
Professional Skills (25 Marks)	
Selection & Conditioning of Materials to last 5 days	10 Marks
Level of difficulty and effective use of techniques	5 Marks
Overall workmanship and professional finish	5 Marks
Innovation of sustainable techniques and mechanics	5 Marks

A detailed criteria overview will be made available to support the participants in interpreting the assessed sections.

An opportunity to present a written brief in response to the Interpretation of Theme will be provided to each participant. More information on this will be provided in the event you are selected for a display at the Show.

TIMING

Judging of the **Floral Design Competition** will commence at 4:30pm on Tuesday 25th March. All designs must be completed by 4:00pm on the same day, with participants required to leave the venue directly thereafter to allow judging to commence in a timely manner.

JUDGING FORMAT

The judging of each display will take place over two stages:

Open Judging – The appointed judging panel will be able to view the creation of each display from 7:00am to 4:00pm on Tuesday 25th March. Judges will not enter any displays during this period and will not communicate directly with competitors on any matters relating to the display or judging.

Formal Judging – The appointed judging panel will begin their formal marking of each display from 4:30pm on Tuesday 25th March.

Failure to adhere to any rules set forth by the Organiser or stipulated in the 'General Terms and Conditions' section below may result in the deduction of points or disqualification from the **Floral Design Competition**.

Each confirmed infringement of the competition schedule and/or general terms and conditions will incur a 5–10-point deduction, with the range based on the severity of infringement.

Infringements include but are not limited to:

- Size violation (width, depth or height)
- Use of prohibited materials
- Less than 60% horticultural materials

The decision of the judging panel is final and conclusive.

FEEDBACK

Participants will have the opportunity to schedule a formal feedback session with a member of the appointed judging panel on Wednesday 26th March during the Show. Feedback sessions must be booked in advance, with detail on how to do so to be provided closer to the Show.

AWARDS AND RECOGNITION

The Show will present the below awards for the **Floral Design Competition**.

Best in Floral Design – Awarded to the highest scoring display from the Floral Design Competition. Only one display can receive this award. This award will be presented at the Floral Competition Award Presentations during Show hours and acknowledged again at the Official Garden Party function.

Medal Awards – Medal awards will be presented to displays based on their overall score using the scoring ranges. All participants achieving a score that earns an award will receive a trophy, with those achieving Gold Medal awards being presented at the Floral Competition Award Presentations held during Show hours on the first day of the event.

GOLD	80-100	SILVER GILT	75-79	SILVER	70-74	BRONZE	60-69
-------------	---------------	--------------------	--------------	---------------	--------------	---------------	--------------

The Event Organiser reserves the right to not award any prizes if the Floral Displays do not meet the minimum standard for the awarding of prizes.

Winning an award at the Show is highly coveted &, profiled accordingly, has long-lasting benefits for the award-winning exhibitors.

AWARD NOTIFICATION

Participants who achieve a 'Gold Medal Award' will be contacted on the evening of Tuesday 25th March to notify them of their achievement. All participants who achieve a 'Gold Medal Award' will also be invited to attend the Official Garden Party on the evening of Wednesday 26th March, where the 'Best in Floral Design' award will be presented. Two complimentary tickets will be provided to all participants who achieve a 'Gold Medal Award.' In the event a ticket has already been purchased, participants will be reimbursed for up to two (2) purchased tickets.

All participants who have not received a score within the 'Gold Medal Award' range will be notified if they have achieved an award when the Show opens on Wednesday 26th March by the signage at their stand.

GENERAL TERMS AND CONDITIONS

1. All participants must adhere to all OH&S requirements as directed by the Organisers, including the completion of any safety briefings or inductions.
2. Participants can utilise the support of additional people on the basis all individuals involved have fulfilled the requirements set out in Point 1.
3. Pre-work on any element of the display is allowed.
4. Participants acknowledge the purpose of 'florals' within their display, as is befitting of the Show. It is expected that the display is made of no less than 60% of botanical materials.
5. Participants must abide by the 'Prohibited Weeds list' provided as part of the Exhibitor Manual. Failure to do so may result in the removal of the display.
6. The designs of displays must be the Competitor's original work and must not infringe the copyright of any third party.
7. All participants are subject to the venue rules and requirements.
8. An Exhibitor Manual will be provided outlining rules and requirements not directly linked to the competition.
9. All displays must be self-standing and cannot be attached to the provided infrastructure or floor to secure in place.
10. The use of artificial flowers, silk flowers, dyed flowers and any form of floral foam is not permitted within the competition, and any participant who uses such materials will be penalised or disqualified from the competition.
11. Participants must provide their own materials, tools, and any other equipment required to install their displays.
12. The installation of any structure may be subject to an engineering review by the Organiser's appointed contractor.
13. Any piece of equipment requiring power within the display must be approved by the Organiser and remains subject to the rules of the venue.
14. It is the requirement of participants to ensure that their display remains in good condition for the duration of the Show. Storage areas will be available for any required additional stock, and early/late access to the venue will be made available for participants to maintain their display.
15. Participants are responsible for the removal of their display from the venue at the conclusion of the Show. Any labour required by the Organiser in removing a display may result in a reduction of the payable fee to the participant.
16. The Organiser reserves the right to dispose of any item that is not removed from the venue by 10:00am on Monday 31st March and shall not be liable to the participant for any loss, expenses, damages or any other consequences arising from such disposal.
17. Participants are responsible for their personal belongs. The Organiser will not be responsible or liable for any injuries, lost, damaged or stolen items or any other losses resulting from participation in the competition.
18. The Organiser reserves the right to amend these terms and conditions without prior notice.